

FRONT VIEW

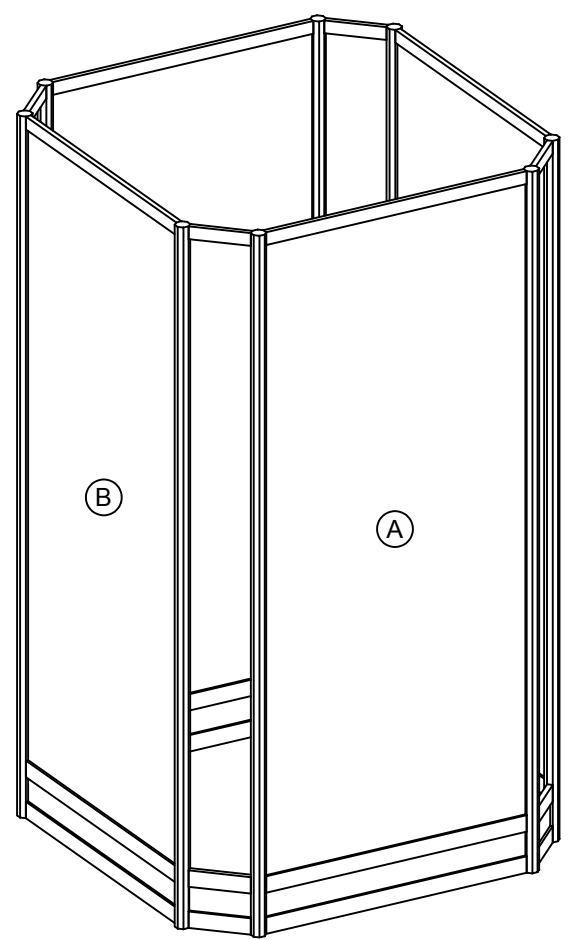

BACK VIEW

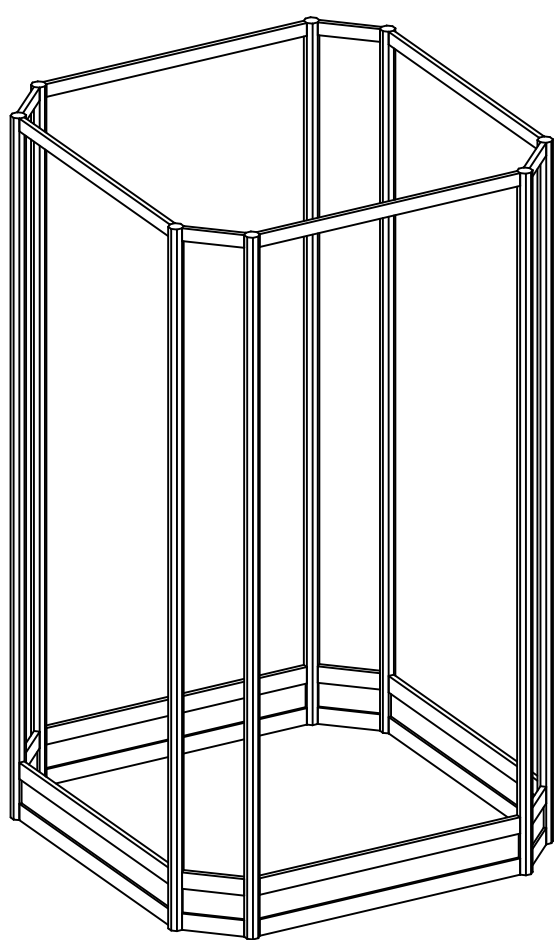

STRUCTURE VIEW

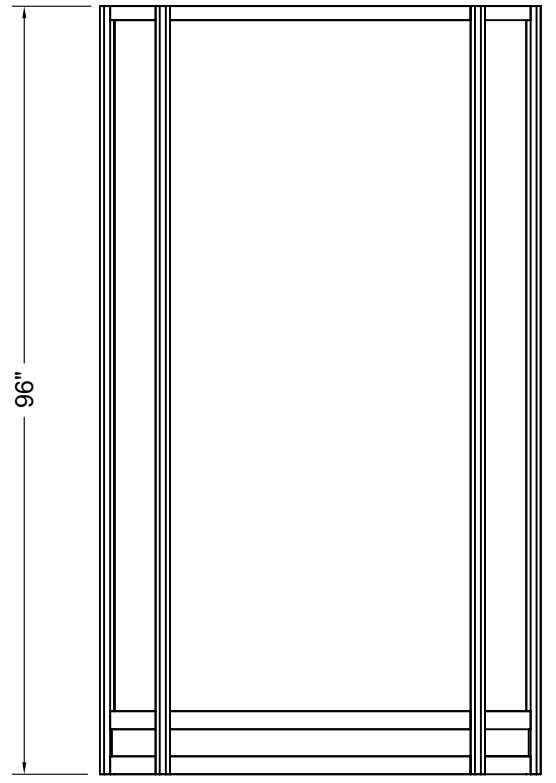

FRONT ELEVATION

Scale: 1/2" = 1'-0"

\*GROMMETS WILL BE PLACED IN ALL FOUR CORNERS OF EACH PANEL FOR ZIP TIES TO SECURE THEM.

SPONSOR COLUMN WRAP

I.D.	Qty	Type	Size	Description	Material	Color
	8	P80	96"	8'-0"	Aluminum	Silver
	4	H45	8"	1/4M	Aluminum	Silver
	4	H45	37-9/16"	1M	Aluminum	Silver
	4	H200	8"	1/4M	Aluminum	Silver
	4	H200	37-9/16"	1M	Aluminum	Silver
A	2	Graphic Panel	38-1/8" x 87"	1M x 8'-0" (H45/H200)	1/4" PVC	Graphic
B	2	Graphic Panel	38-1/8" x 87"	1M x 8'-0" (H45/H200)	1/4" PVC	Graphic

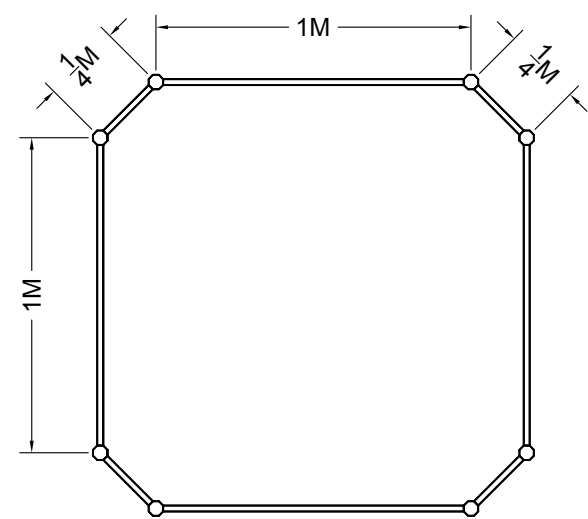

PLAN VIEW

Scale: 1/2" = 1'-0"

LESS THAN 30 DAYS OUT

\* 0 0 4 5 2 5 2 0 0 1 . 1 0 1 6 . 0 \*

MORE THAN 30 DAYS OUT

\* 0 0 4 5 2 5 2 0 0 1 . 1 0 1 6 . 1 \*

ORDERED BY;

ORDER DATE;

DUE DATE;

PG#

2

PPL#

5238032

CNC PAGE  
CNC PATH

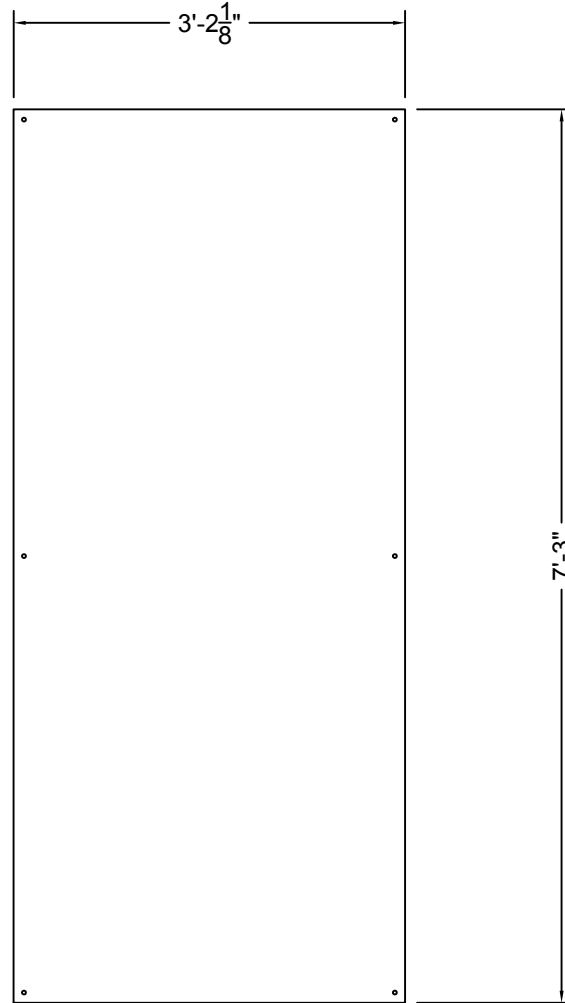

NAME: Panel A  
MATERIAL: PVC  
QTY: 2  
NOTES:  
NEED TO CUT:

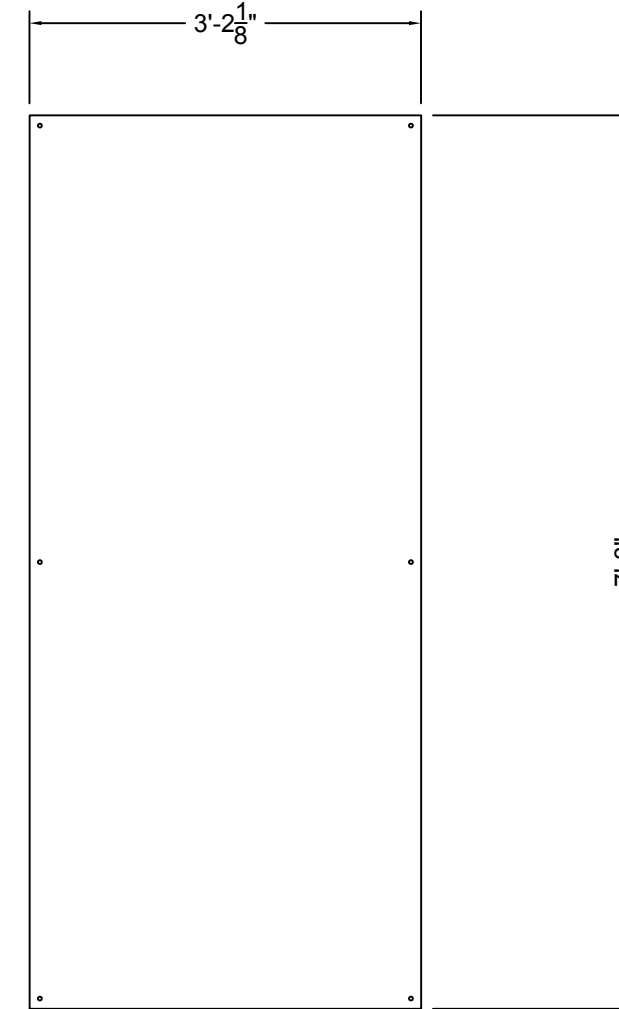

NAME: Panel B  
MATERIAL: PVC  
QTY: 2  
NOTES:  
NEED TO CUT:

CNC PROFILES  
Custom

CNC- DXF FILEPATH:

O:\SERDC\\_Orlando\2019\HIMSS ANNL CONF - 452520\Exposition\CAD\Details\HIMSS19 OutdoorColumnWrap 5238032 CNC.dxf