

HIMSS26 Booth Selection Information

January 30, 2025



Today's Presenters



Laura Goodwin
Sales Operations Lead



Scott Sherpe
*Vice President,
Marketing*



Rebecca Washler
*Vice President,
Sales*



Elli Riley
*Vice President,
HIMSS Global Conference and Exhibition*

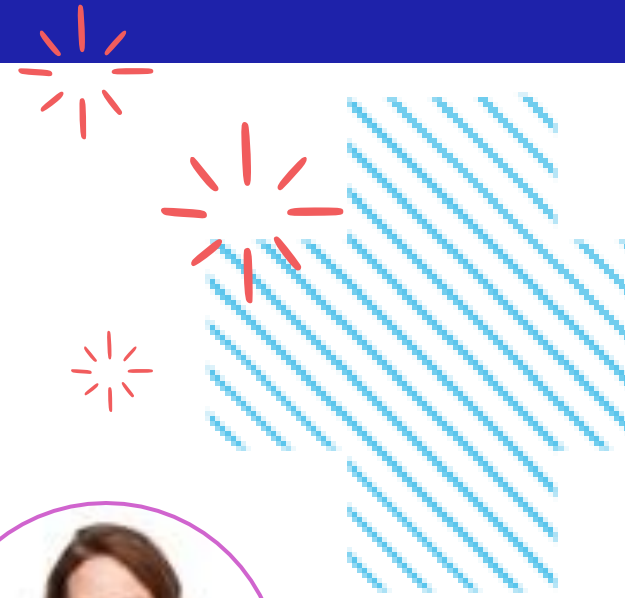

Reminders

A few reminders before we begin:



Your line was muted when you joined the call

If you have any questions throughout the presentation, please save until Q&A time as we may answer later in the presentation. During Q&A time, please use the Q&A box at the top of your screen.



This webinar is being recorded

The recording and slides will be sent to all attendees via email within a few hours after the presentation. Please utilize the links throughout the slides for additional information.

Agenda

- HIMSS25 Registration Update
- HIMSS26 Dates
- Booth Selection Timeline
- HIMSS26 Booth Selection Opportunities
- Deposit Requirements
- Floor Plan and Logistics
- Additional Booth Selection Information & Resources
- HIMSS Global Conference and Exhibition Premier
Conference Supporter Program
- Questions

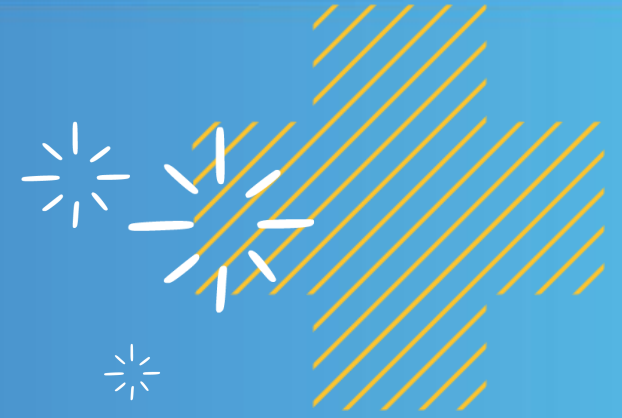

HIMSS25 Registration Update

HIMSS25 Registration Update

26% up in
Provider
Executive Pass

28% up in
Nurses

3% up in CXO
Registrations

95% up in
Government
Passes

5% up in
International
Attendees

43% up in
Press Passes

HIMSS25 Registration Update

75%

of attendees make or influence decisions

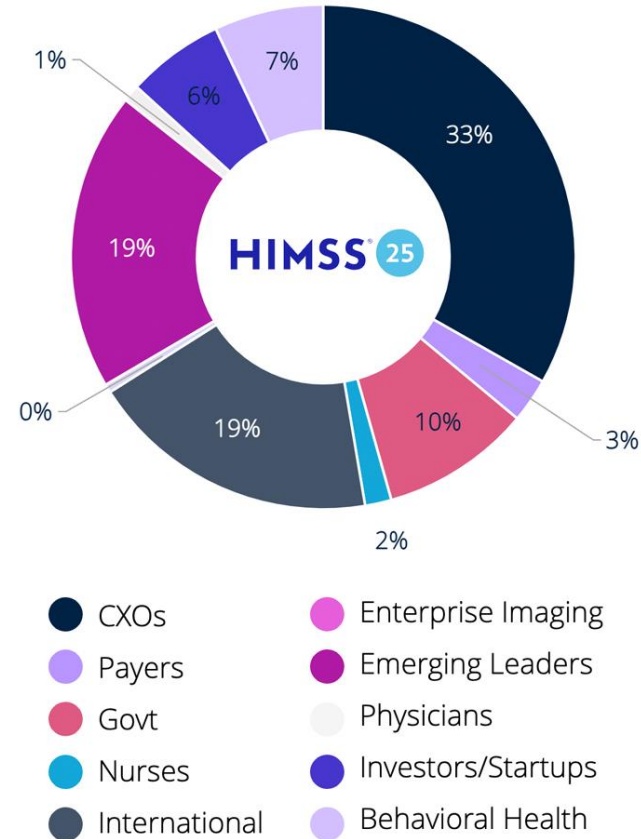

What's New and Exciting at HIMSS25?

- AI Pavilion
- Emerge Innovation Experience
- Health Equity Preconference Forum
- New Education Formats
- Expanded Networking
- New Show App
- Powerhouse Keynote Simone Biles
- You

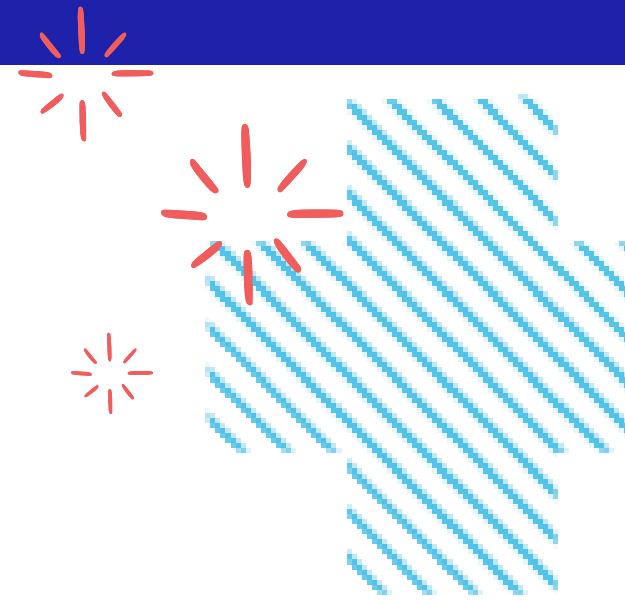



HIMSS26 Booth Selection

HIMSS26 Dates

- **Global Health Conference Dates**
 - March 9-12, 2026 (Monday – Thursday)
 - Las Vegas | The Venetian Expo Center
- **Preconference Sessions, Opening Reception**
 - Monday, March 9
- **Exhibition Dates**
 - March 10-12 (Tuesday – Thursday)



HIMSS26 Booth Selection Timeline

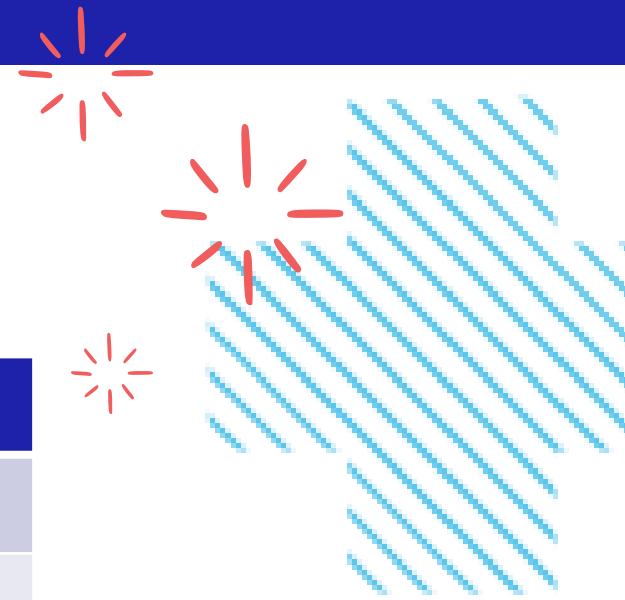

Dates	Selection Group
February 3, 2025	Anchor Selection Begins
February 24-28, 2025	Top 100 companies in priority point order select virtually
March 3-6, 2025	Onsite Booth Selection at the Venetian Expo Center Room: 304

Note:

- Booth selection appointment times are scheduled in exhibitor priority point order
- Booth selection order is based on points as of December 31, 2024

HIMSS26 Rebook Benefits

- **Space:** Access to *premium* booth locations in high-traffic areas
- **Sponsorships:** Access to *prime* sponsorships and speaking times
- **Rebook Rates (new benefit):** Take advantage of the lowest rates available during rebook period (ends April 14, 2025)
- **Maximize Planning Time:** Commit now and allow additional time to plan your booth design, marketing materials, and on-site activations

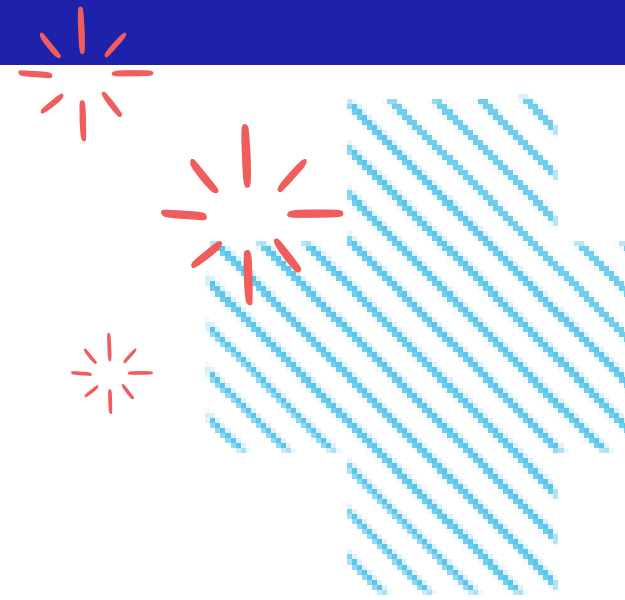

HIMSS26 Rebook Opportunities

- Standard Exhibition Space
- Meeting Place Rooms
- Meeting Pods
- Vendor Headquarters
- Specialty Pavilions
- Select Sponsorships



Standard Exhibition Space

- Space begins at 10'x10' (100 sq. ft)
- (5) badges per 10'x10' space
- Listing on HIMSS26 website and mobile app

	Corporate Member		Non-Member	
Booth Size	Rebook Rate Feb 3 – Apr 14, 2025	Standard Rate Apr 15, 2025 – Mar 9, 2026	Rebook Rate Feb 3 – Apr 14, 2025	Standard Rate Apr 15, 2025 – Mar 9, 2026
10'x10'	\$5,900	\$6,400	\$6,600	\$7,100
10'x 20'	\$10,400	\$11,400	\$11,800	\$12,800
10'x 30'	\$15,600	\$17,100	\$17,700	\$19,200
20'x 20'	\$20,800	\$22,800	\$23,600	\$25,600
Larger than 20'x20'	\$45 per sq. ft.*	\$50 per sq. ft.*	\$52 per sq. ft.*	\$57 per sq. ft.*

*For island booths larger than 20'x20, there is a \$850 fee per corner

Meeting Place Rooms

- Meeting room structure with carpet and locking door
- 10'x 20': (1) Conference table and (8) boardroom chairs
- 20 x 20: (2) Conferences tables and (16) board room chairs
- One (42") monitor, Electrical, Internet line (shared T1 line)
- Cleaning (if room left unlocked overnight)

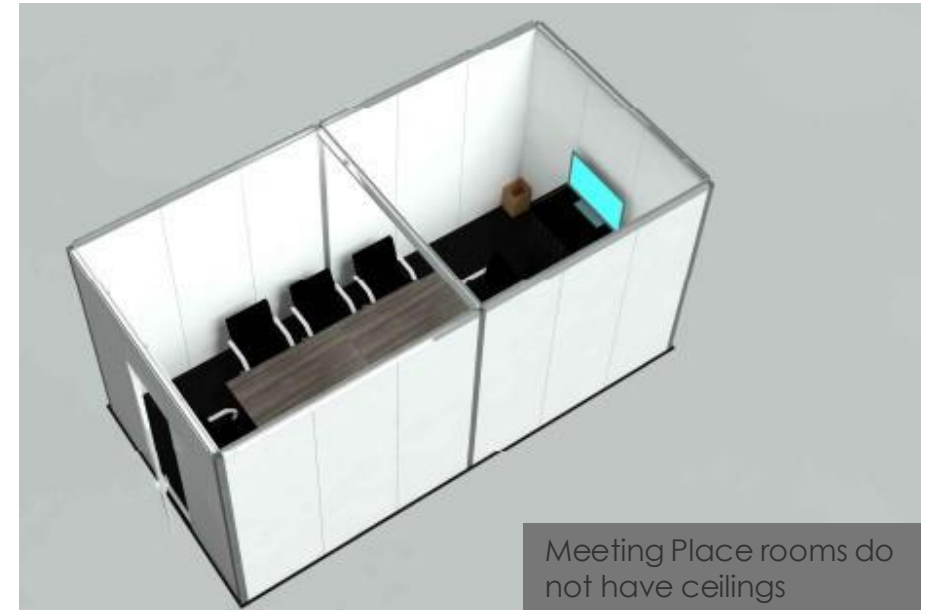

- Conference Badges

- 10'x20': 10
- 20'x20': 20

	Corporate Member		Non-Member	
Size	Rebook Rate Feb 3 – Apr 14, 2025	Standard Rate Apr 15, 2025 – Mar 9, 2026	Rebook Rate Feb 3 – Apr 14, 2025	Standard Rate Apr 15, 2025 – Mar 9, 2026
10' x 20'	\$20,600	\$21,600	\$22,700	\$23,800
20'x 20'	\$35,800	\$37,300	\$39,400	\$41,000

Meeting Pods

- 10'x10' semi-private meeting space
- Low wall structure with company logo
- Table with 4 chairs
- Electrical and Wi-Fi access
- Carpeted floors
- Conference Badges – 5



Meeting Pod example

	Corporate Member		Non-Member	
Size	Rebook Rate Feb 3 – Apr 14, 2025	Standard Rate Apr 15, 2025 – Mar 9, 2026	Rebook Rate Feb 3 – Apr 14, 2025	Standard Rate Apr 15, 2025 – Mar 9, 2026
10'x10'	\$14,500	\$15,100	\$16,000	\$16,600

Vendor Headquarters*

- 10'x 20' hard walled structure (8' high wall) with a lockable door (no ceiling)
- Identification sign with your company logo
- Carpet

*Must have an exhibit space to purchase

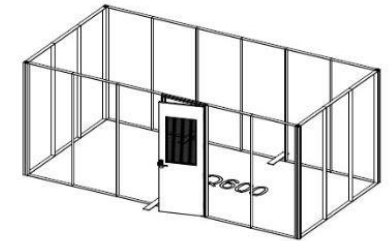
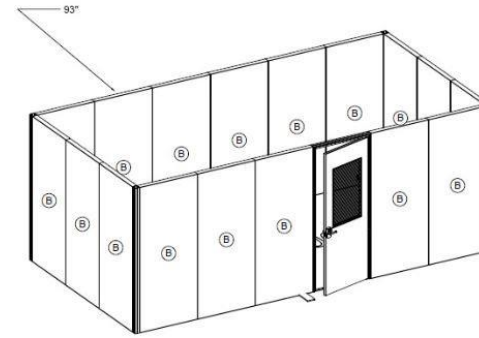

VH0600 STRUCTURE VIEW

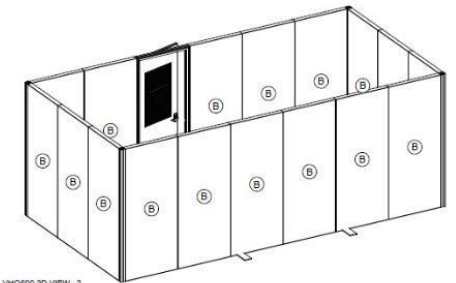

VH0600 3D VIEW - 2

	Corporate Member		Non-Member	
Size	Rebook Rate Feb 3 – Apr 14, 2025	Standard Rate Apr 15, 2025 – Mar 9, 2026	Rebook Rate Feb 3 – Apr 14, 2025	Standard Rate Apr 15, 2025 – Mar 9, 2026
10'x20'	\$8,400	\$8,600	\$9,200	\$9,500

Specialty Pavilions

Topic-focused areas on the show floor, with turnkey exhibit and thought leadership opportunities, designed for you to reach your desired audience.

Cybersecurity Command Center

Compliance & Privacy	Application Security	Threat Management	User Authentication	Risk Management
----------------------	----------------------	-------------------	---------------------	-----------------

Artificial Intelligence

AI / Machine Learning	Robotics	RPA	AR/VR
-----------------------	----------	-----	-------

Business Operations Pavilion – NEW!

Claims Processing	Revenue Cycle	Consulting	IT Infrastructure	Prior Authorization
-------------------	---------------	------------	-------------------	---------------------

Patient Experience and Wellness

Digital Health and Wellness	Patient-Provider Platforms and Portals	Virtual Care	Behavioral Healthcare
Remote Patient Monitoring	Telehealth	Personal Health Devices and Wearables	

Government Connections Plaza

Specialty Pavilion Turnkey Packages

Each package includes structure and furnishings shown, graphic production and installation, electrical, monitor(s), keyboard, mouse, internet, badges and option for 20-minute speaking session

Kiosk

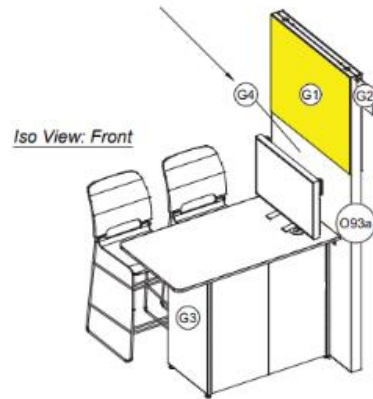

10'x10'

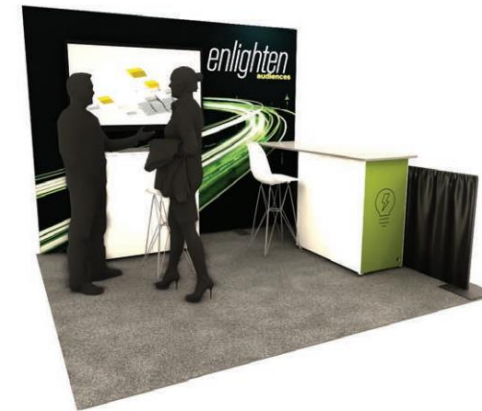

10'x20'



20'x20'



Specialty Pavilions

Package	Corporate Member		Non-Member	
	Rebook Rate Feb 3 – Apr 14, 2025	Standard Rate Apr 15, 2025 – Mar 9, 2026	Rebook Rate Feb 3 – Apr 14, 2025	Standard Rate Apr 15, 2025 – Mar 9, 2026
Kiosk Non-Speaking	\$9,200	\$9,600	\$10,100	\$10,600
Kiosk with Speaking	\$16,200	\$16,600	\$17,800	\$18,300
Turnkey 10'x10'	\$16,400	\$17,000	\$18,000	\$18,700
Turnkey 10'x10' with Speaking	\$23,400	\$24,000	\$25,700	\$26,400
Turnkey 10'x20' Non-Speaking	\$28,500	\$29,700	\$31,400	\$32,700
Turnkey 10'x20' with Speaking	\$35,500	\$36,700	\$39,000	\$40,400
Turnkey 20'x20' Non-Speaking	\$41,200	\$42,900	\$45,300	\$47,200
Turnkey 20'x20' with Speaking	\$48,200	\$49,900	\$53,000	\$54,900

Rebook Sponsorship Opportunities*

Sponsorship	Corporate Member		Non-Member	
	Rebook Rate Feb 3 – Apr 14, 2025	Standard Rate Apr 15, 2025 – Mar 9, 2026	Rebook Rate Feb 3 – Apr 14, 2025	Standard Rate Apr 15, 2025 – Mar 9, 2026
*First rights of refusal may apply				
Booth Furnishing Package	\$2,300	\$2,550	\$2,500	\$2,750
Bistro Table	\$5,200	\$5,600	\$5,700	\$6,100
Industry Solution Speaking Session	\$26,500	\$29,000	\$28,500	\$31,000
Exhibitor Main Stage Speaking Session – Premium Time (Tues/Wed)	\$26,450	\$29,450	\$29,000	\$32,000
Exhibitor Main Stage Speaking Session – Standard Time (Thurs)	\$23,250	\$25,750	\$25,000	\$27,500
Enhanced Exhibitor Listing	\$3,200	\$3,500	\$3,200	\$3,500
Daily Email Deals – Premium	\$8,100	\$8,600	\$8,900	\$9,400
Daily Email Deals - Standard	\$5,800	\$6,100	\$6,300	\$6,600
Lunch and Leams - Premium	\$33,500	\$38,500	\$35,000	\$40,000
Lunch and Leams - Standard	\$28,500	\$33,500	\$30,000	\$35,000
Brunch Briefing – Premium	\$23,500	\$28,500	\$25,000	\$30,000
Brunch Briefing Standard	\$18,500	\$23,500	\$20,000	\$25,000
Hosted Buyers Meetings	\$5,200	\$5,400	\$5,700	\$5,900
Hosted Buyers Lounge*	\$30,000	\$35,000	\$35,000	\$40,000

Rebook Sponsorship Opportunities*

Sponsorship <small>*First rights of refusal may apply</small>	Corporate Member		Non-Member	
	Rebook Rate <small>Feb 3 – Apr 14, 2025</small>	Standard Rate <small>Apr 15, 2025 – Mar 9, 2026</small>	Rebook Rate <small>Feb 3 – Apr 14, 2025</small>	Standard Rate <small>Apr 15, 2025 – Mar 9, 2026</small>
Electronic Message Billboards	\$23,700	\$25,000	\$26,000	\$27,300
Venetian Expo Lobby LED Ribbon	\$13,328	\$13,900	\$14,628	\$15,200
Palazzo Rotunda Monitor	\$13,328	\$13,900	\$14,628	\$15,200
Exhibit Hall Blade Displays	\$13,328	\$13,900	\$14,628	\$15,200
Restaurant Row Monitors	\$13,328	\$13,900	\$14,628	\$15,200
Venetian Expo Elevator Cabs	\$4,750	\$4,950	\$5,200	\$5,400
Tote Bags/Backpacks*	\$55,000	\$60,000	\$60,000	\$65,000
Attendee Badge Lanyard*	\$32,700	\$37,700	\$35,000	\$40,000
Exhibitor Badge Lanyard*	\$28,000	\$33,000	\$30,000	\$35,000
Hotel Key Cards (Venetian & Palazzo)*	\$32,250	\$37,250	\$35,000	\$40,000
Hotel Key Cards (Wynn & Encore)*	\$16,750	\$18,750	\$18,000	\$20,000
Conference Pens	\$15,000	\$16,600	\$16,400	\$18,000
Experiential Vending Machine*	\$37,000	\$42,000	\$40,000	\$45,000
Blood Drive	\$3,000	\$3,300	\$3,500	\$3,800
Puppy Park*	\$43,000	\$48,000	\$45,000	\$50,000
Stair Clings	\$21,000	\$22,800	\$23,000	\$24,800

Rebook Deposit Information

Total Rented Space <i>(includes standard space, meeting place rooms, meeting pods, vendor headquarters, and specialty pavilions)</i>	Deposit Amount
100 sq. ft.	\$1,500
200 – 1,000 sq. ft.	\$4,800
1,100 – 2,500 sq. ft.	\$8,500
2,600 sq. ft. or above	\$22,500
Deposit Due: April 14, 2025 Remaining Deposit Schedule: <ul style="list-style-type: none"> • May 30, 2025: Remaining balance: 50% due • August 29, 2025: Remaining balance: 100% due 	
Sponsorships 50% due May 30, 2025; 100% due August 29, 2025	
Signed Agreement Due: Thursday, March 6, 2025	
<p>Please note that Informa charges a 3% fee for any credit card payments. The fee will be added to the invoice at the time payment is processed.</p>	

Accepted Methods of Payment

Check	Credit Card
<p>Check made payable to: Informa Exhibitions U.S. Construction</p> <p>Bring onsite with you to HIMSS25 or</p> <p>Mail to: PO Box 411724 Boston, MA 02241-1724</p>	<p>Pay by credit card by logging into your Exhibitor Dashboard; a link will be provided on the invoice</p> <p>Note: a 3% fee will be applied to credit card payments in any single transaction</p>

ACH/Wire Instructions:

Bank: Bank of America Account Name: Informa Exhibitions U.S. Construction & Real Estate, Inc.

Address: 222 Broadway, New York, NY 10038 Phone: 800-432-1000

Swift Code: BOFAUS3N ABA Number: (WIRE: 026009593) or (ACH: 021000322)

Account Number: 483094322036 Federal Tax ID# is 80-0961214

Informa accepts Purchase Orders and requires payment in full prior to the start of the Event.

Priority Points Opportunities!

- Pay 50% of the space balance due
 - **15 priority points!**
- Pay 100% of the space balance due
 - **30 priority points!**
- Payment must be received no later than April 14, 2025
- Fill out the Post HIMSS25 Exhibitor Survey
 - **20 priority points!**
- Points will be applied post HIMSS25 conference



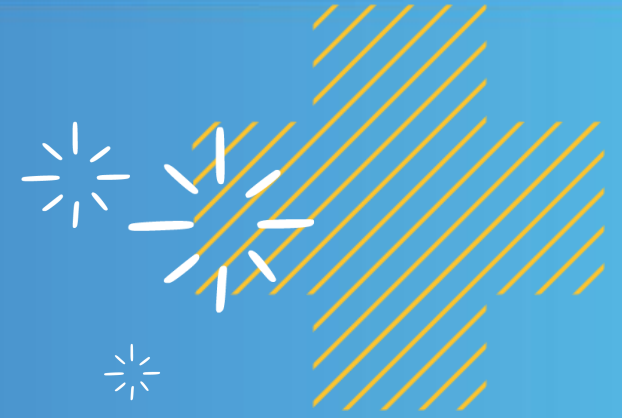

Booth Selection Appointment Process

Top 100 Booth Selection Appointments

- If you are selecting in the top 100, emails will be sent the week of February 3, 2025, with appointment times and login information
- All Top 100 appointments are CENTRAL TIME
- All companies receive the same appointment link (the same Microsoft Teams meeting will run all day) so we ask you to call in during your appointment timeframe only
- Please be on time and stick to the schedule as we have back-to-back appointments scheduled for the entire day. If you do not select a booth during the scheduled meeting, we will move onto the next person
- The booth space contract must be signed by the last day of the onsite booth selection, Thursday, March 6, 2025
- All deposits are due by April 14, 2025

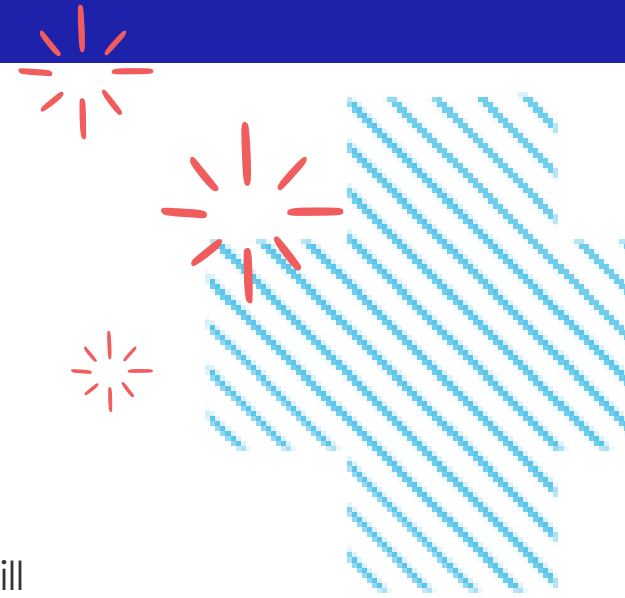

Onsite Booth Selection Appointments

- Appointment times will be sent out the week of February 10, 2025
- Appointment times are in Pacific Time Zone since we will be in Vegas
- Booth Selection will take place at the Venetian Expo Center, Room 304
- Please look for signage directing you to the room or visit any of our information desks for assistance
- Please show up to appointment 5-10 minutes early to view the floor plan before selecting your space
- Please be prepared to sign the booth space contract (online) after your appointment.
- Once you arrive to the room, there will be instructions on where to go next
- The booth space contract must be signed by the last day of the onsite booth selection, Thursday, March 6, 2025
- All deposits are due by April 14, 2025

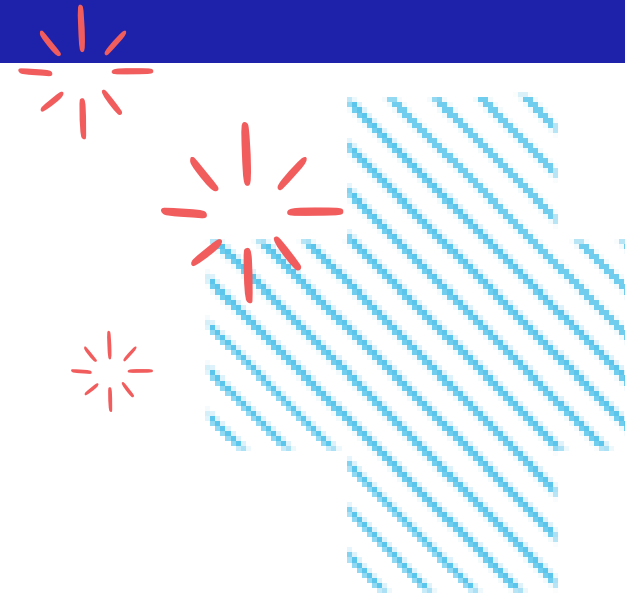

Onsite Booth Selection Location and Hours

- Location:
 - The Venetian Expo Center
 - Level 1, Room 304
- Hours:
 - Monday, March 3: 1:00 PM – 5:00 PM
 - Tuesday, March 4: 2:00 PM – 5:00 PM
 - Wednesday, March 5: 8:00 AM – 5:00 PM
 - Thursday, March 6: 8:00 AM – 3:00 PM



What if I can't make my appointment?

- Your appointment is in the top 100?
 - Please work with your HIMSS sales manager to schedule a time to select your space prior to HIMSS25

OR

- Come to the HIMSS26 booth selection room onsite during booth selection hours
- Your appointment is onsite but you can't make the assigned time?
 - Stop by the HIMSS26 booth selection room anytime after your scheduled appointment, during booth selection hours
- You have an onsite appointment time, but are not attending HIMSS25 and still want to make your selection for HIMSS26?
 - Please contact your sales manager or Laura Goodwin for information on alternative appointment options

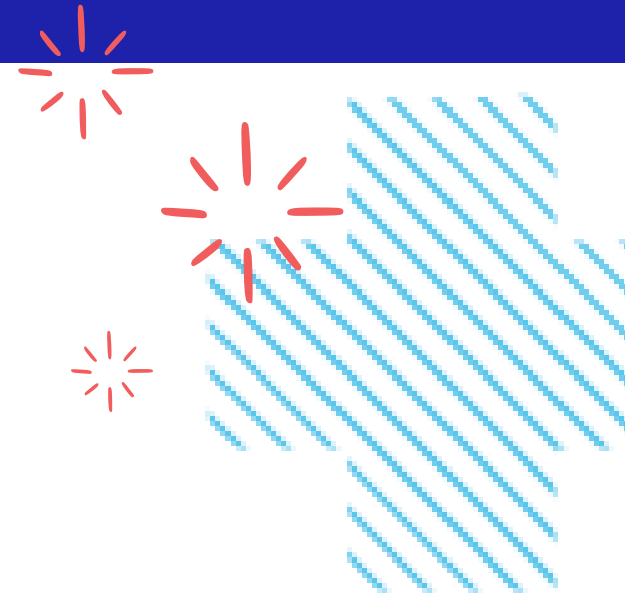



Floor Plan and Logistics

HIMSS26 Conference Layout:



Level 2



Level 3



Level 4

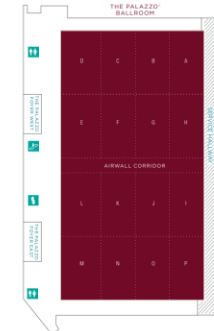

Level 5

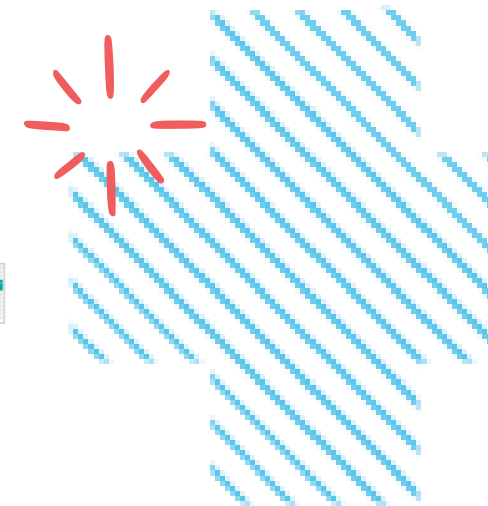

Venetian: Level 2

Anchor locations

Specialty Pavilions:

- Patient Engagement & Wellness
- Business Operations
- First-Time Exhibitors
- Hosted Buyers
- Main Stage

— '20 aisles

★ Entrance

Escalator Entrance

HIMSS 2026

03/09/26 - 03/12/26

VENETIAN EXPO & CONVENTION CENTER - LEVEL 2 - LAS VEGAS, NV

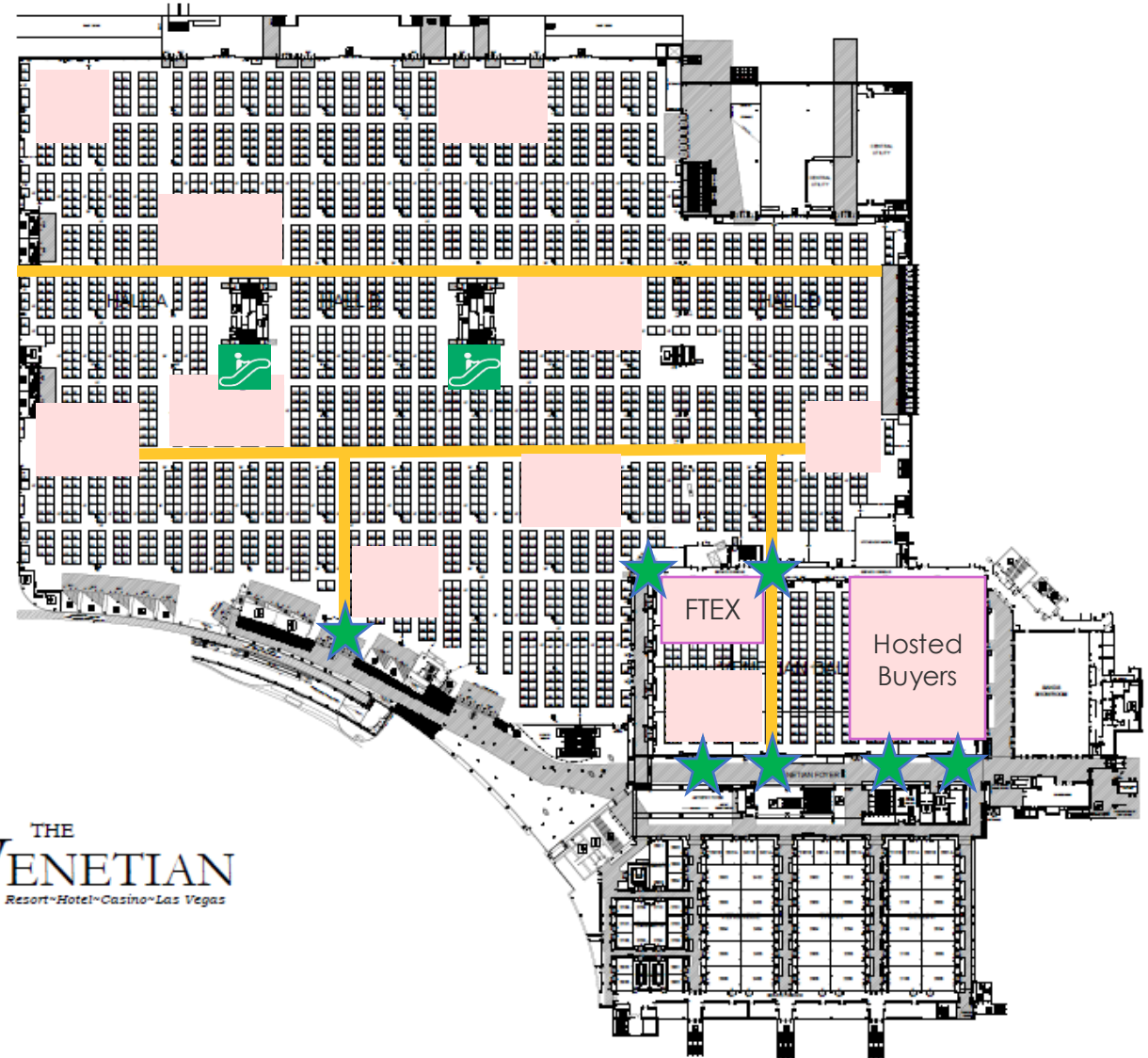

THE
VENETIAN
Resort™ Hotel™ Casino™ Las Vegas

Venetian: Level 1

Specialty Pavilions:

- Cybersecurity
- AI Pavilion
- Government Plaza
- Start-up

Meeting Place/Pods

Food Concessions



Entrance



Escalator Entrance

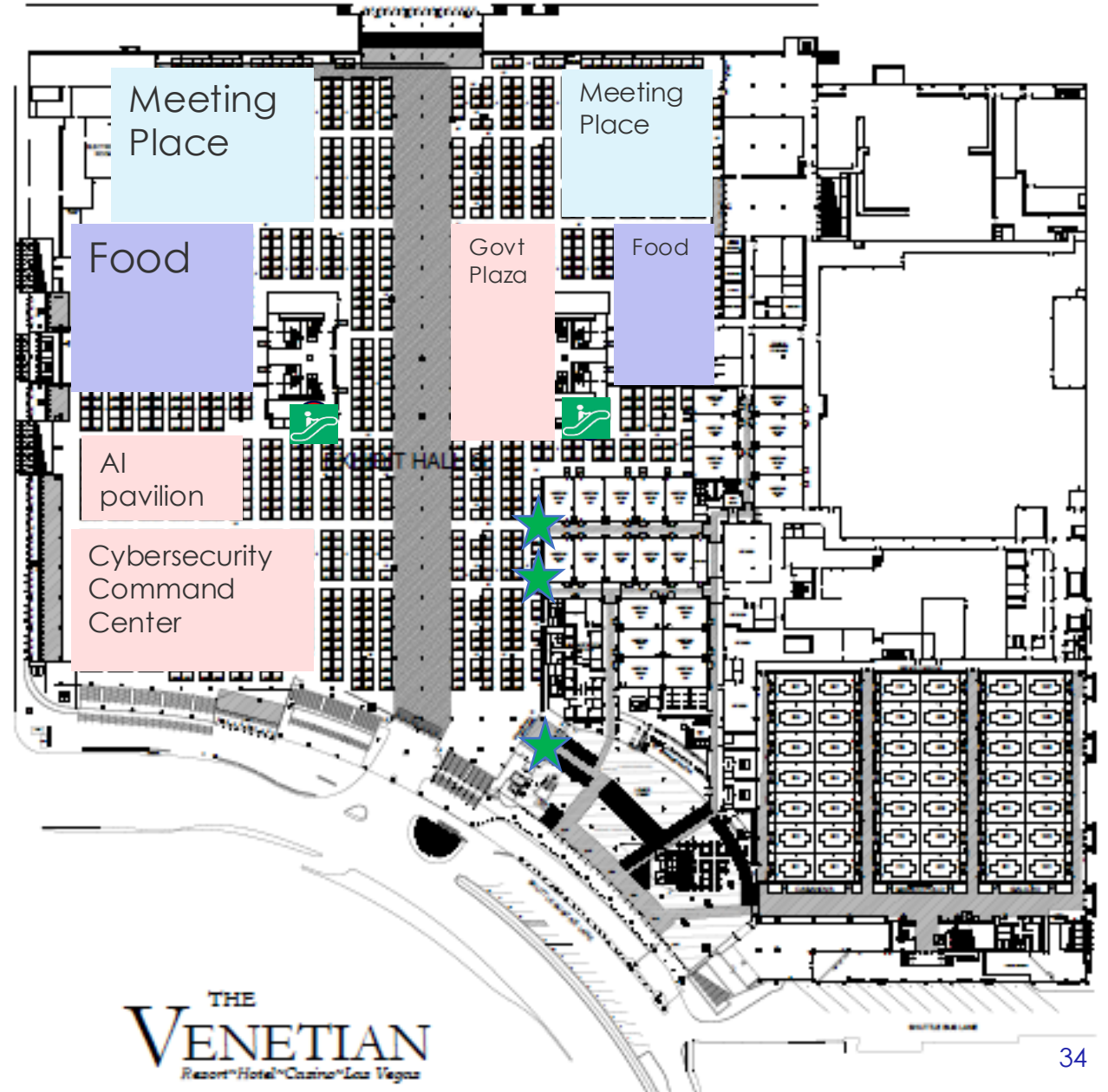

General Rules of the Show

- HIMSS26 will be a preset floorplan. Booths will not be resized until onsite booth selection is over
- Hall A-D ceiling height is 32' and the maximum height for your booth or hanging sign is 24'.
- Venetian Ballroom ceiling height is 22-28' and maximum height for hanging signs or structure is 16'. This ballroom has limited rig points
- Hall G ceiling height is 13' and the maximum height for your booth is 12'. Hanging signs are not allowed in Hall G
- Columns can be wrapped if within booth, but need to leave specialty accessories exposed (fire extinguisher medical equipment etc.)
- Columns range from 2 – 3.5 feet in diameter
- All electrical/networking will be pulled from the ceiling

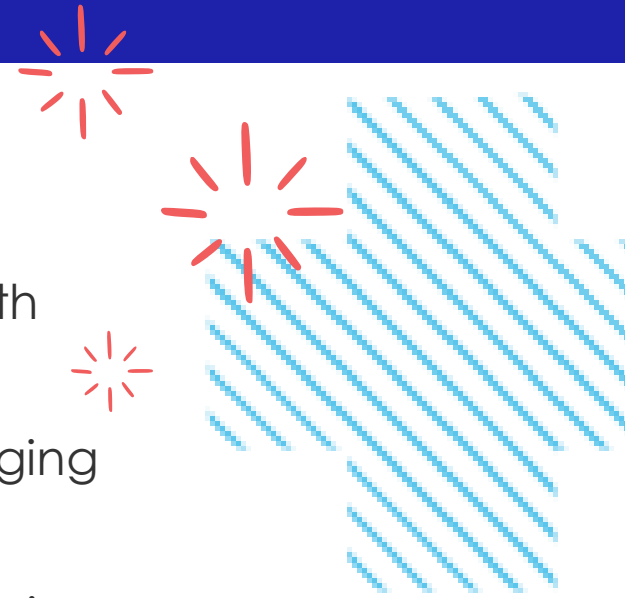

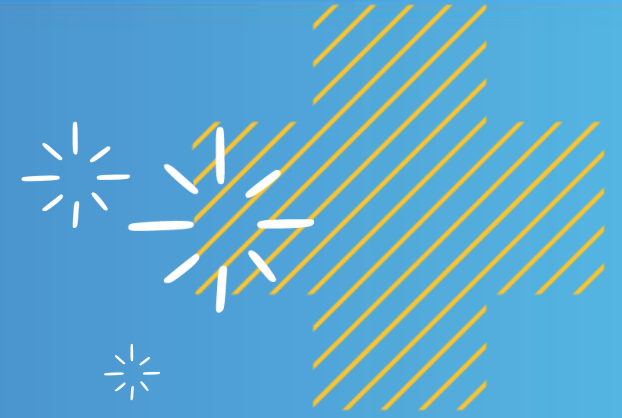

Additional Booth Selection Information and Resources

HIMSS26 Booth Wait List

- Must have a booth at HIMSS26 to be added to the wait list
- Booths of 20 x 20 or larger can be placed on the wait list.
 - (10'x10' or 10'x20' booths will not be placed on the wait list but continue to monitor the live floor plan and if you see an open location contact your sales representative)
- Booth moves are done based on priority points as of December 31, 2024
- You will be removed from the booth wait list after one successful move
- Wait list will end August 28, 2025
- Exhibitor is responsible for the price difference with a booth move
- [HIMSS26 Booth Wait List Link](#)
- To be placed on this wait list, please stop by the check-in desk in the booth selection room or contact salesinfo@himssconference.com

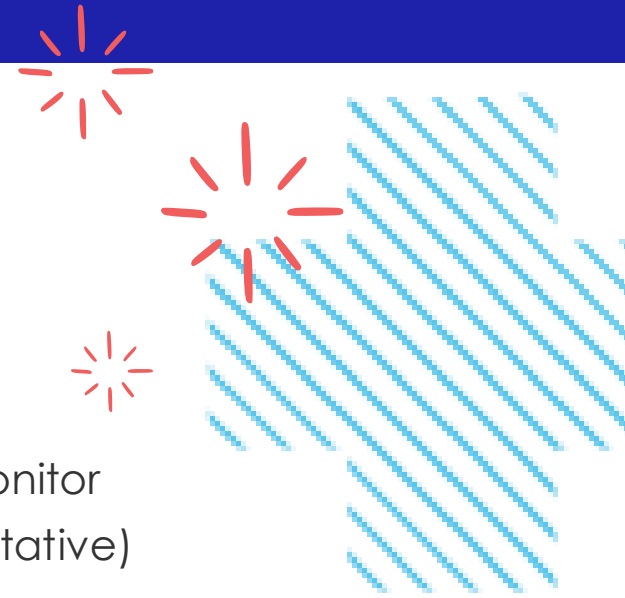

HIMSS26 Booth Selection Resources

- Live floor plan link*: This will be provided before your appointment
- Questions about booth selection? Contact your Sales Manager or:
 - Laura Goodwin – Laura.Goodwin.US@informa.com
- Corporate Membership Information: Corporatememberinfo@himss.org
- [HIMSS25 Priority Point Information](#)

*Please check the floor plan before your booth selection appointment for the most up-to-date version

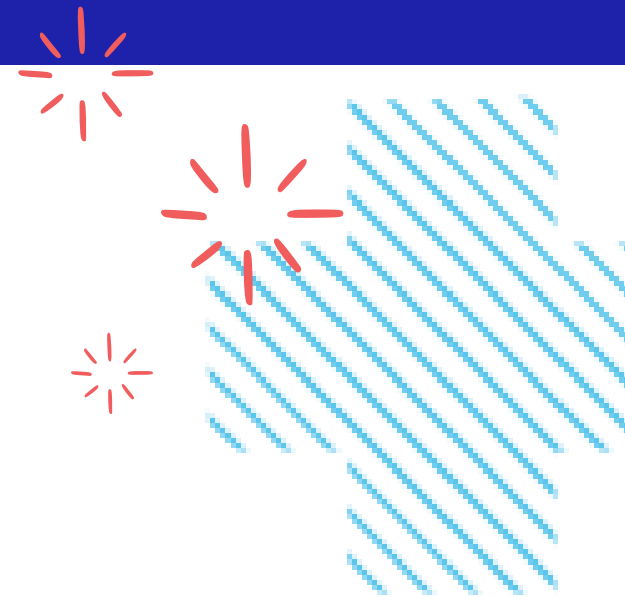

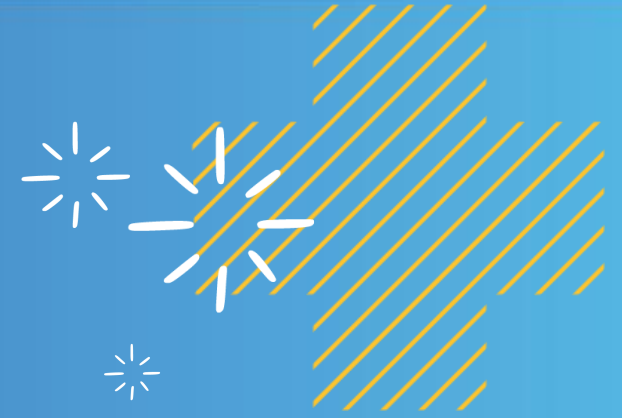

HIMSS Global Conference & Exhibition Premier Conference Supporter Program

Premier Conference Supporter Program

Global Conference and Exhibition Premier Conference Supporter Program

Eligibility	Pre-Show Benefits	Onsite Benefits
<ul style="list-style-type: none"> Global Conference participation (space/sponsorships) with total spend greater than \$175,000 	<ul style="list-style-type: none"> Early Move-in when time/space permits* Waiving of subletting rule to allow co-exhibitors in booth (additional co-exhibitor listing fee per company applies)* First choice on hotel selection before HIMSS Corporate Members - based on priority points (if eligibility is achieved by August 2025) Additional hotel rooms at the Diamond identified hotels, number to be determined by May 2025. Complimentary attendee list Logo Recognition with link to company website on Global Conference Premier Conference Supporter exhibitor web page Logo recognition in the exhibition countdown email that is sent to all pre-registered attendees (sent two weeks prior to show) Pre-show detail of registrants – pre-show deep dive breakdown of titles and worksite Complimentary enhanced listing (Package 2) within exhibitor search on Conference website HIMSS to deliver premium conference supporter press release to credentialed press three weeks prior to global conference. Prominent banner placement on the HIMSSConference.org website Editorial in GC newsletter preshow 	<ul style="list-style-type: none"> Complimentary vendor headquarter at the Convention Center* Company logo and booth number recognition throughout the Convention Center 75 additional priority points 25 additional priority points* Meet and greet with press in attendance at Global Conference (cocktail reception) Logo and booth number recognition on exhibition lobby electronic entrance units Company and booth number highlighted on way finders located throughout the exhibit hall Company logo and booth number recognition on all printed maps onsite Daily detail on registration numbers sent directly to your email each day of conference <div data-bbox="1651 1029 2390 1093" style="background-color: #333; color: white; padding: 5px;">Post-Show Benefits</div> <ul style="list-style-type: none"> Post Show attendee list Deep dive detailed Global Conference attendee demographics <p data-bbox="1651 1253 1888 1282">*Anchor benefits</p>



Questions?

Questions?

Contact Laura.Goodwin.US@informa.com or your Sales Representative

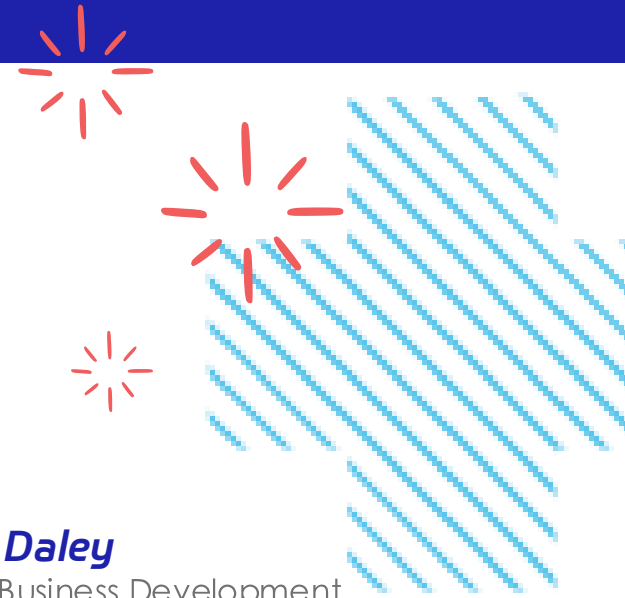

Deborah Caruso

Senior Sales Executive
312.305.1734
Deborah.Caruso@informa.com



Jim Collins

Director, Sales
312.848.1067
Jim.Collins@informa.com



Jessica Daley

Director, Business Development
312.305.4309
Jessica.Daley@informa.com



Saba Emmanuel

Business Development Manager
416.844.8293
Saba.Emmanuel@informa.com



Laura Goodwin

Sales Operations Lead
312.305.3975
Laura.Goodwin.US@informa.com



Matt McDonough

Business Development Manager
917.245.8125
Matt.McDonough@informa.com



John O'Neill

Business Development Manager
929.651.0328
John.Oneill@informa.com



Evalyn Pelzer

Sales Support Specialist
Evalyn.Pelzer@informa.com



Rebecca Washler

Vice President, Sales
312.305.3952
Becky.Washer@informa.com

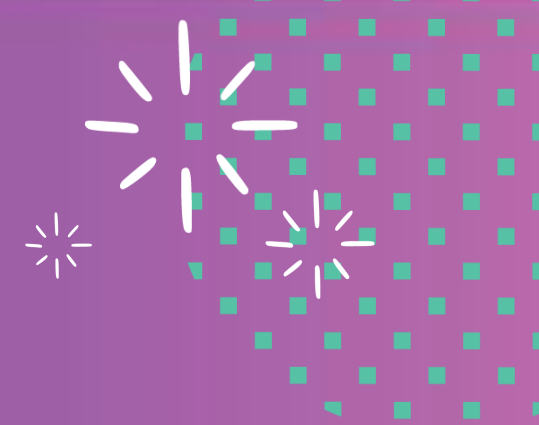

Thank you